

100 PALLETS PER HOUR AT 85% EFFICIENCY

Benefits of the Robotic Pallet Dismantler

Double your output
Process more teardown pallets
Consistent throughput

Eliminate operator fatigue
Expand your available labor
Increased operator efficiency

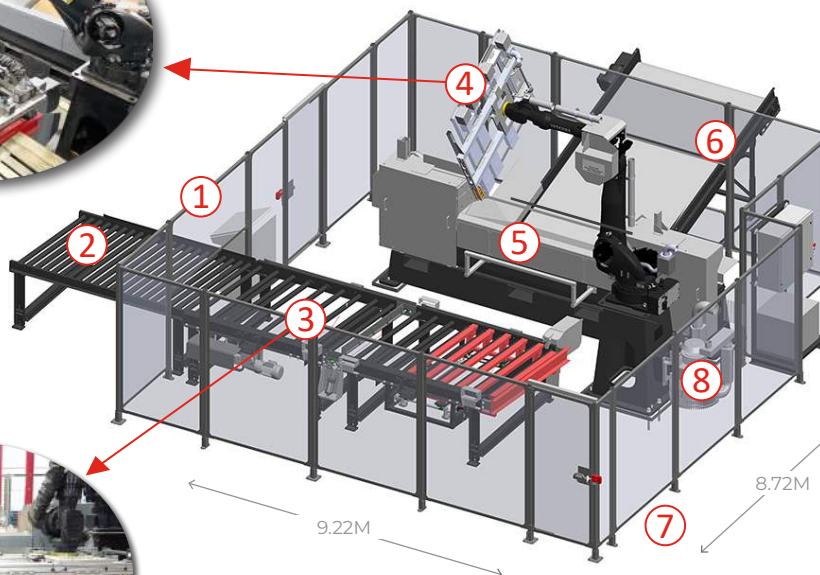

(minimum ceiling height of 4.57M required)

Components

Infeed Section

1. Operator Station
2. Gravity Infeed Conveyor
3. Powered Conveyor

Optimization Section

4. Robot End of Arm Tool
5. Alliance Automation Bandsaw

Outfeed Section

6. Outfeed Conveyor

System Section

7. Safety Guarding
8. Vacuum System

CONTACT US TO LEARN MORE

419-238-2520

info@allianceautomation.com

THE SAFEST WAY TO DISMANTLE PALLETS

ALLIANCE SUPPORT

- ▶ Designed to fit your facility
- ▶ Install and training included
- ▶ Daily production report available
- ▶ Remote service access
- ▶ One year warranty
- ▶ Assigned service team

PALLET TYPES

- 762 x 762 mm to
1524 x 1524 mm
- ▶ Euro Pallets
EUR 1-6
 - ▶ Stringer Pallets
 - ▶ Skid Pallets
 - ▶ Block Pallets

STANDARD OPTIONS

- ▶ Mechanical Robot End of Arm Tool for EPAL
- ▶ Spare parts package
- ▶ Guard extensions
- ▶ Netting over top of cell
- ▶ Saw brake
- ▶ Left hand, right hand, or straight layouts

NON-STANDARD OPTIONS

- ▶ Additions to guarding package
- ▶ Control panel relocation
- ▶ Any other infeed conveyor angle
- ▶ Tipper infeed
- ▶ Lift table infeed
- ▶ Turntable outfeed