

ALLIANCE AUTOMATION

INNOVATE. CREATE. **ADVANCE.**

SORT & REPAIR SYSTEMS

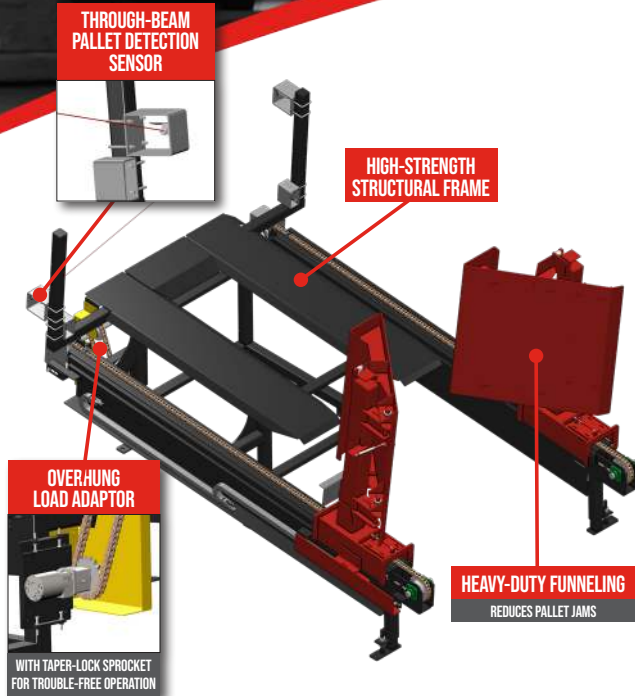

ACCUMULATOR

Specifications

Pallet Sizes:

30" x 30" to 48" x 48"

Dimensions:

143" L x 94.5" W x 84.75" H

Weight:

3,500 lbs.

Electrical Requirements:

480/3PH

Hydraulic Requirements:

1200 PSI

ARMADILLO CONVEYOR

Specifications

Pallet Sizes:

30" x 30" to 48" x 48"

Dimensions:

47" x 83.25" x 115.75"

Weight:

2,000 lbs.

Electrical Requirements:

480/3PH

Top of Chain:

33" infeed





BACKSTOPS

SINGLE • DOUBLE & MORE AVAILABLE

Specifications

Dimensions:

single: 55.5" x 59.5" x 143"

double: 55.5" x 119" x 143"

Weight:

single: 1100 lbs.

double: 2200 lbs.



HEAVY-DUTY
FLIP STOPS



HEAVY-DUTY NFPA TIE ROD
PNEUMATIC CYLINDER

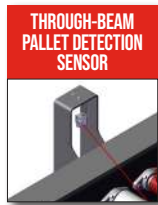

THROUGH-BEAM
PALLET DETECTION
SENSOR

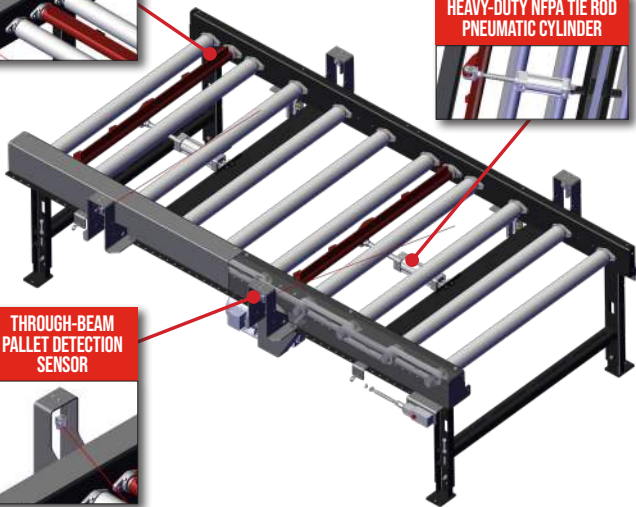

CONVEYOR

Specifications

Pallet Size:

48" x 40"

Dimensions:

43" eff width: 39.5" H x 62.5" W

51" eff width: 39.5" H x 70.5" W

Width (effective):

43" or 51"

Weight:

5' Section: 500 lbs.

10' Section: 1,000 lbs.

Electrical Requirements:

480/3PH

Rollers:

3.5"

Top of Roller:

33" +/- 2" adjustable legs

Air Requirements:

80 PSI

LINE STACKER

Specifications

Pallet Size:

48" x 40"

Dimensions:

58" x 75.5" x 154.25"

Weight:

2,350 lbs.

Electrical Requirements:

480/3PH

Hydraulic Requirements:

1200 PSI

Top of Chain:

33"

Air Requirements:

80 PSI

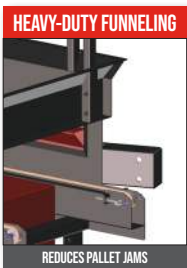

HEAVY-DUTY FUNNELING

REDUCES PALLET JAMS

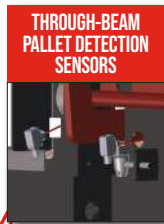

THROUGH-BEAM
PALLET DETECTION
SENSORS

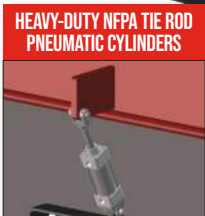

HEAVY-DUTY NFPA TIE ROD
PNEUMATIC CYLINDERS



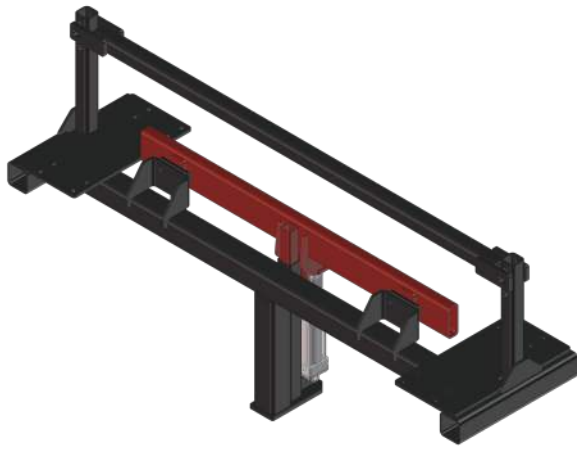

PINCH GATE

Specifications

Pallet Sizes:

30" x 30" to 48" x 48"

Dimensions:

66.25" x 34.5" x 17"

Weight:

250 lbs.

Air Requirements:

80 PSI

SWEEP

Specifications

Pallet Size:

48" x 40"

Dimensions:

82.5" x 72.75" x 41"

Width (effective):

51"

Weight:

1,000 lbs.

Electrical Requirements:

480/3PH

Hydraulic Requirements:

1200 PSI

Top of Roller:

33" +/- 2" adjustable legs

Air Requirements:

80 PSI

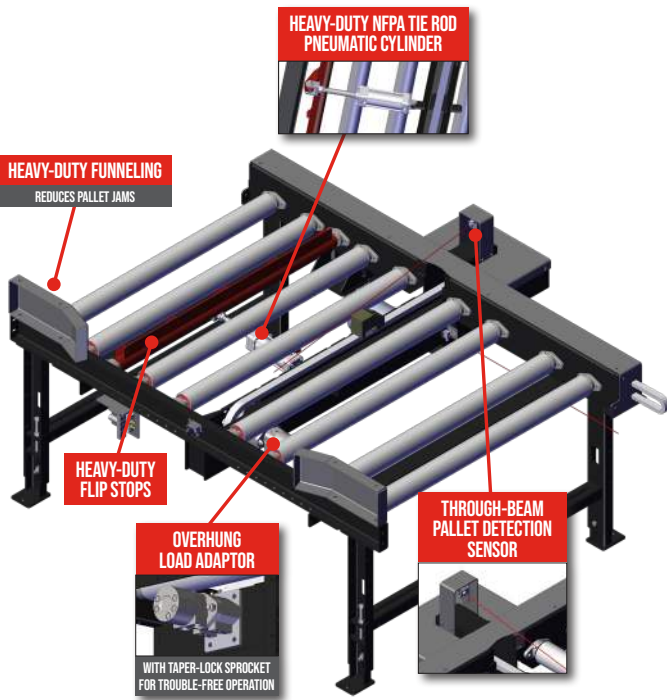

SWOOP TABLE

Specifications

Pallet Sizes:

30" x 30" to 48" x 48"

Dimensions:

58.5" x 57.5" x 88"

Weight:

600 lbs.

Top of Roller:

33"



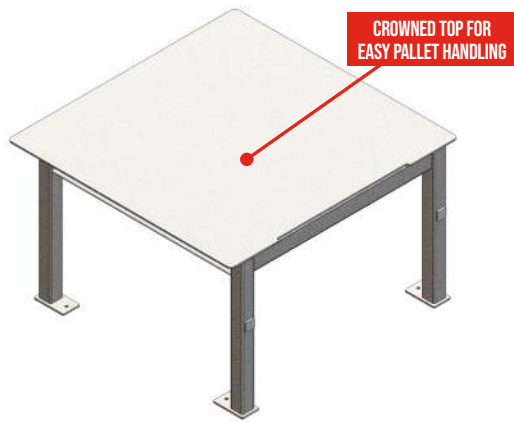

REPAIR TABLE

EASY TRANSFER TO CONVEYOR

Specifications

Dimensions:

53" W x 54" L x 32" H

Weight:

500 lbs.

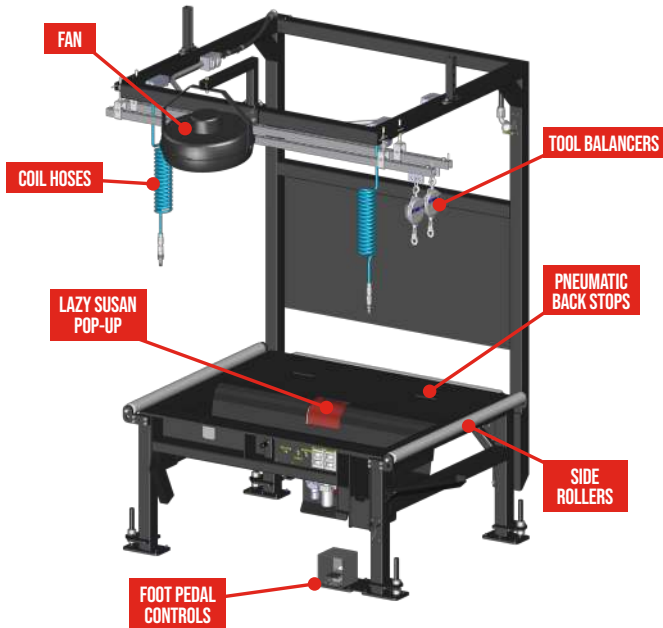

REPAIR TABLE

Specifications

Table Top Dimensions:

51" W x 59.5" L x 30.5" H

Total Height:

113"

Weight:

1,400 lbs.

Electrical Requirements:

120v

Air Requirements:

80 PSI

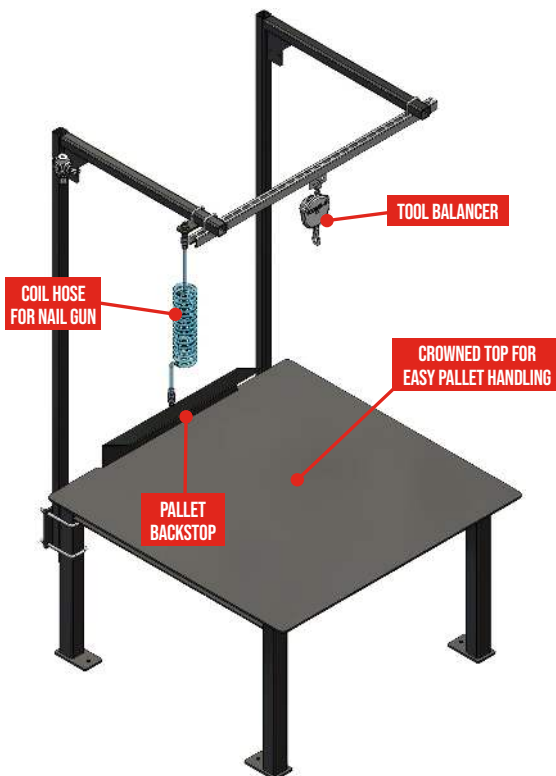

REPAIR TABLE

Specifications

Dimensions:

53" W x 54" L x 100" H

Weight:

625 lbs.

Air Requirements:

80 PSI

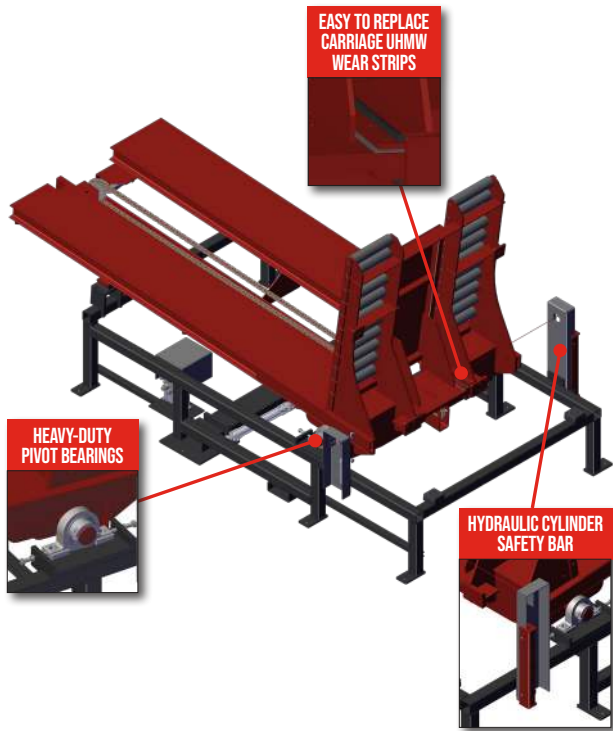

TIPPER

Specifications

Pallet Sizes:

30" x 30" to 48" x 48"

Dimensions:

154.5" L x 81.5" W x 76.5" H

Weight:

4,750 lbs.

Electrical Requirements:

480/3PH

Hydraulic Requirements:

1200 PSI

Top of Roller:

30" infeed

Pallet Stack Height:

20 pallets