



3306.93lb
Rated Load
Capacity



3.36mph
Max. Safety
Driving Speed



118.11in
Fork Lifting Height



122.05in
Min. Stacking
Aisle Width

VNP15

COUNTERBALANCE STACKER AGV



Taking advantages of 3D SLAM navigation and 3D laser perception module, the project implementation period is shortened and the AGV has high reliability; The AGV has 360-degree safety protection with customizable forks and other tools based on different scenarios, which provides high level safety, great flexibility, and strong adaptability.



VNP15

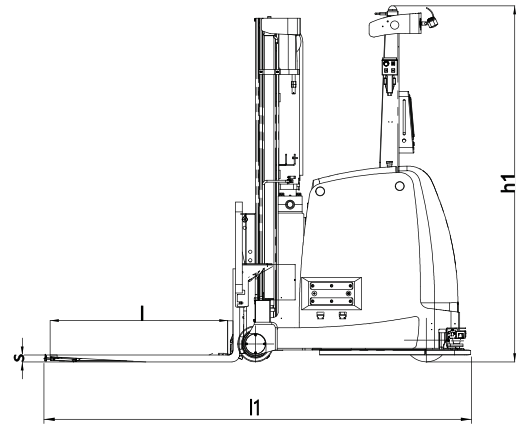
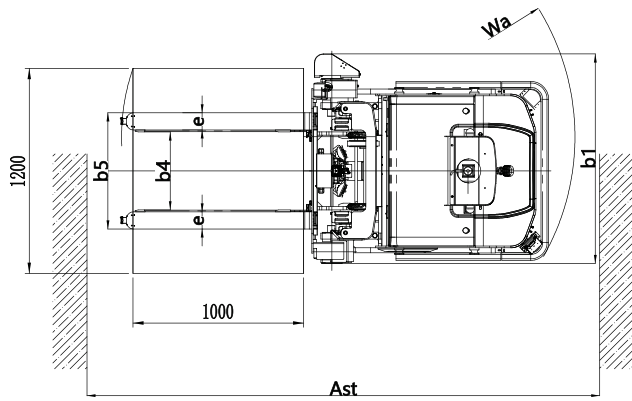

TECHNICAL SPECIFICATIONS

Body Weight	2900kg (6393.41lb)	Fork Lifting Height	3000mm (118.11in)
Vehicle Dimensions (l1/b1/h1)	2543x1344x2085mm (100.12x52.91x82.09in)	Rated Load Capacity	1500kg (3306.93lb)
Fork Dimensions (l/e/s)	1040x100x40mm (40.94x3.94x1.57in)	Load Center Distance	500mm (19.69in)
Optional Fork Dimensions Series	890/1190/1340/1490/1640/1790mm (35.04/46.85/52.76/58.66/64.57/70.47in)	Min. Turning Radius	1490mm (58.66in)
Fork Outer Width	560/680mm (22.05/26.77in)	Stacking Accuracy	±10mm/±0.5° (±0.39in/±0.5°)
Fork Inner Width	336/456mm (13.23/17.95in)	Operation Mode	Automatic / Manual Handheld
Positioning Method	3D SLAM	Battery Type	Lithium iron phosphate
Perception Method	3D Laser scanner	Voltage/Battery Capacity	24V/270Ah
Goods Pick-up Self-adaptability	±100mm/±10° (±3.94in/±10°)	Charging Mode	Manual/ Automatic Charging

MOTION PERFORMANCE

Straight Forward Speed (Full-Load/Empty-Load)	1.3m/s, 1.5m/s (2.91mph, 3.36mph)	Backward Turning Speed (Full-Load/Empty-Load)	0.3m/s, 0.6m/s (0.67mph, 1.34mph)
Straight Backward Speed (Full-Load/Empty-Load)	0.6m/s, 0.6m/s (1.34mph, 1.34mph)	Lifting Up Speed (Full-Load/Empty-Load)	100mm/s, 150mm/s (0.22mph, 0.34mph)
Forward Turning Speed (Full-Load/Empty-Load)	0.3m/s, 0.6m/s (0.67mph, 1.34mph)	Lifting Down Speed (Full-Load/Empty-Load)	180mm/s, 100mm/s (0.40mph, 0.22mph)

ENVIRONMENTAL REQUIREMENT

Min. Stacking Aisle Width (Pallet Size L*W:1200*1000mm, Across Forks On Length)	3150mm (124.02in)	Ground Flatness	±5mm/m ² (±0.20in/m ²)
Min. Turning Aisle Width (Pallet Size L*W:1200*1000mm, Across Forks On Length)	2152mm (84.72in)	Max. Climbing Capability (Full-Load/Empty-Load)	5%, 5% (3°, 3°)
Working Temperature	-5°C~40°C	Max. Groove Width	30mm (1.18in)
Working Humidity	20%~95%	Max. Step Height	10mm (0.39in)

SAFETY PROTECTION

Front	Laser Scanner Protection + Anti-Collision Bumper	Side	Laser Scanner Protection + Anti-Collision Bumper
Rear	Laser Scanner Protection	Other	Emergency Stop Button + Acousto-Optic Alarm
Top	Photoelectric Sensor + Ultrasound Scanner		

* Customizable fork length, fork outer width, and supporting legs outer width; With duplex mast option, the lifting height can reach 3000mm, 3500mm, 4000mm, and 4500mm. With triplex mast option, the lifting height can reach 4500mm (body weight varies slightly with different mast selections); Available fork type options: Side shifter and adjustable forks; Other available options: 5G communication, battery heating, battery trolley for battery swap, safety anti-collision bumper, loads over height detection, UWB safety system, barcode scanner, dash camera, RFID reader, etc. Maximum load capacity varies with lifting height, please refer to load capacity curve.

Due to iterative upgrades on products, some of the specifications being listed above and the appearance of the products may not be able to change in time. For details, please contact our salespersons.